



Rodney Hunt
A ZURN Company
Butterfly Valves

Butterfly

Valves



Rodney Hunt Streamseal™ Butterfly Valves



Flow Control for the Power and Municipal Marketplace

- Cast
- Fabricated
- Rubber-Covered

The cast, rubber-covered, and fabricated Streamseal Butterfly Valves manufactured today by Rodney Hunt Company are the latest in a series of butterfly valve designs previously offered by AC Valve, Inc., and first introduced by Allis Chalmers Corporation over 50 years ago. While the basic Streamseal design manufactured today remains consistent with Streamseal Butterfly Valves of the past, advances in metallurgy, actuation equipment technology, and manufacturing techniques make the Rodney Hunt Streamseal Butterfly Valve better than ever before for all heavy duty flow control applications.

Rodney Hunt Company is an international leader in the design and manufacture of cast and fabricated gates, valves, and actuation equipment for water control applications. Located in Orange, Massachusetts, Rodney Hunt facilities include a modern foundry, advanced fabrication and machining areas, continually updated CAD capabilities, and hydrostatic testing facilities. Interdisciplinary design engineering expertise, and a commitment to ongoing technological development help Rodney Hunt achieve outstanding levels of customer service, quality, and value on every project

Rodney Hunt designs and manufactures a broad range of Streamseal cast, fabricated, and rubber-covered butterfly valves 24" and larger to meet your flow control needs. For over 50 years, coal, petroleum, natural gas, nuclear, hydro and geothermal facilities and municipalities have been using Streamseal Butterfly Valves manufactured by Allis-Chalmers, AC Valve, and now Rodney Hunt.

Butterfly valves play a critical role in the efficient performance of a power or treatment facility. Streamseal Butterfly Valves from Rodney Hunt are known for their ruggedness, serviceability, and lower life-cycle cost. Rodney Hunt also works with designers, contractors, and operators to ensure that the appropriate valve is selected for each application.



**SIZES
24"-192"
and Larger**

**AWWA
Standard C504**

Cast, fabricated or rubber-covered



The *Streamsea*[™] Butterfly Valve is designed to be the easiest valve to install and operate... with minimum maintenance required.

Design Versatility

- Pre-engineered to meet various applications.
- Cast or fabricated body and disc options.
- Hard rubber coating available for corrosive service.
- Design, cast, fabricate, machine and test ...at one location.
- Rodney Hunt manual, pneumatic, hydraulic, and electric actuation options.
- Hydrostatic testing facilities.

Domed Disk Design

- Ductile iron for maximum strength.
- No foundry coring for consistent quality.
- Exceptional hydraulic stability.
- Less dynamic torque for reduced actuator sizing and energy requirements.
- Less head loss, reduced pumping costs.
- Full rubber coating (optional).

Flow-Through and Low Profile Fabricated Disc Designs

- Rugged bridge truss (flow-through).
- Heavy-duty trunnions.
- Full rubber coating (optional).

Resilient 360° Lock in Seating

- Disc seat seals against stainless steel mating surface.
- Lock-in seat secured by easily replaced stainless steel retainer ring.
- Adjustable without special tools.
- 304 stainless steel body seat provides corrosion resistant mating surface.

Space-Saving Body Design

- Meets all requirements of AWWA Standard C-504.
- Variety of end connections available.
- Self-lubricating bushings for continuous low-friction operation.
- Two-way, field-adjustable thrust bearing permits flexibility in valve and actuator orientation.



The Streamseal™ Butterfly Valve



Design Features

Meets established requirements of AWWA Standard C504.

1. Shafts-stainless steel ASTM A276 Type 304 standard.
Monel and 316 stainless steel shafts available.
2. Valve body-ASTM A126 Class B or C cast-iron or ASTM A516 Grade 70 fabricated steel, depending on size and pressure class.
3. Valve disc-ASTM A536 Grade 65-45-12 ductile iron or ASTM A516, Grade 70 fabricated steel, depending on size and pressure class.
4. Shaft seals-bronze packing gland with square TFE impregnated Teflon packing.
5. Shaft bearings-Corrosion resistant, self-lubricated sleeve type.
6. Taper pins-Tangential pins of stainless steel ASTM A582 Type 416HT securely fasten disc to stub shafts. Tangential pinning reduces pin shear stresses. Pins held in place by stainless steel jam nuts and washers.
7. End cover-Same material as body. Buna-N O-ring seal.

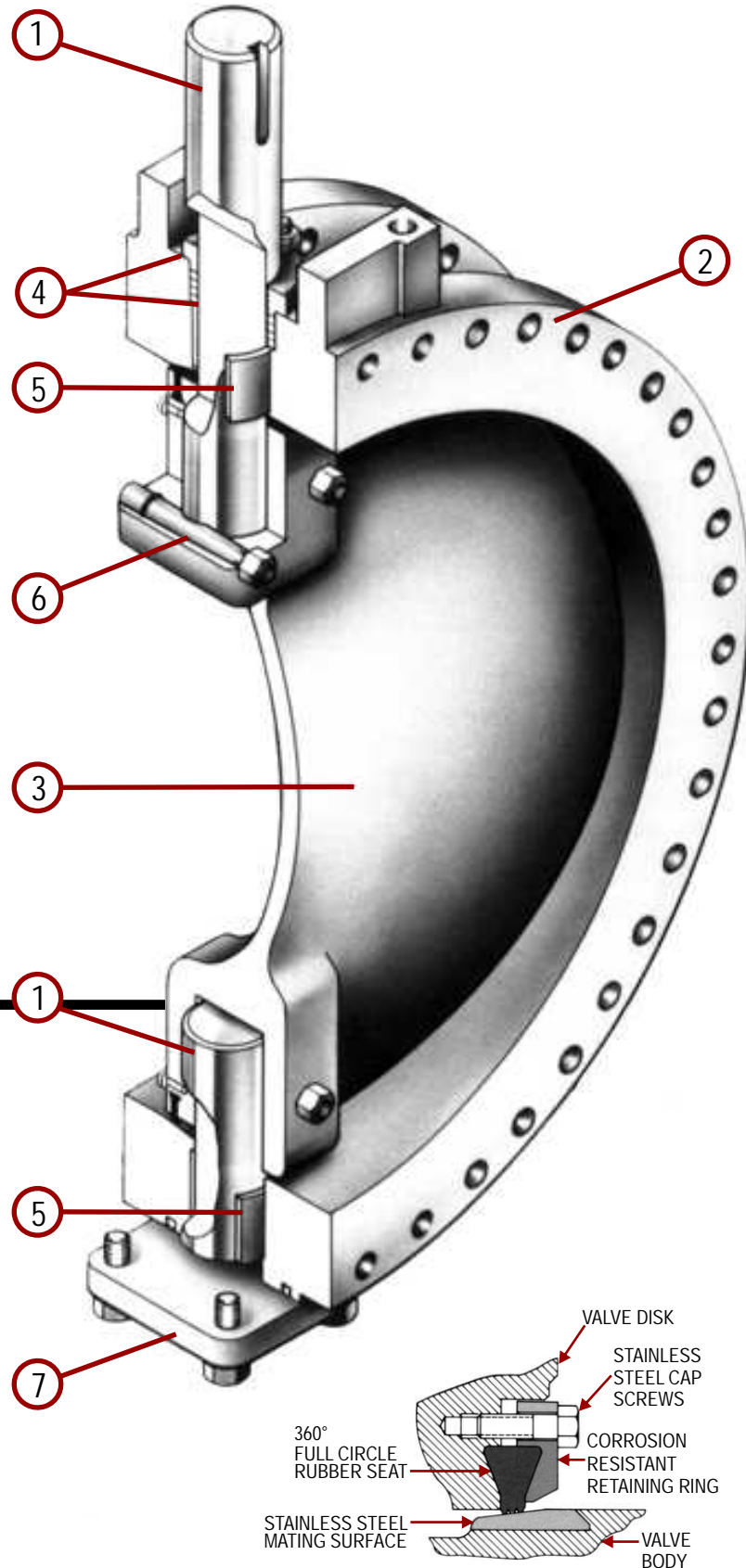

Lock in Rubber Seat Design

Offers positive retention, total rubber control, and maximum user flexibility.

- Rubber seat fully locked-in by dovetail configuration. Does not require adhesives for retention.
- Rubber edge is serrated, reducing seating torque requirements.
- Cap screws do not penetrate rubber eliminating any tendency to "waffle" or "scallop" the seating edge.
- Two-way adjustable. By changing the torque on the cap screws, the amount of rubber projection can be controlled to provide drip-tight closure under all line conditions.
- Independent of line pressure for positive shut-off.

Sizes 24" and Larger

- Exclusive domed disc design.
 - Solid cast disc without internal coring.
 - Concave/convex curvilinear shape provides excellent hydraulic stability, even in turbulent flows.
 - Maximum reliability in on/off or throttling service.
 - Reduced head loss, lower pumping costs.
 - Reduced dynamic torques and torque reversals. Less actuator energy requirements.
 - Ductile iron (ASTM A536 Grade 65-45-12) to withstand shock loads.
- Resilient lock-in seat is secured to the domed disc edge by a corrosion resistant retainer ring.
- Variety of disc seat materials available.
- Body Mating Surface: Type 304 stainless steel.
- Shafts: Type 304 stainless steel.
- Taper pins: Tangentially positioned to prevent shear failure, O-ring sealed.
- End connections: Flanged, mechanical joint, grooved, plain, or combinations as required.

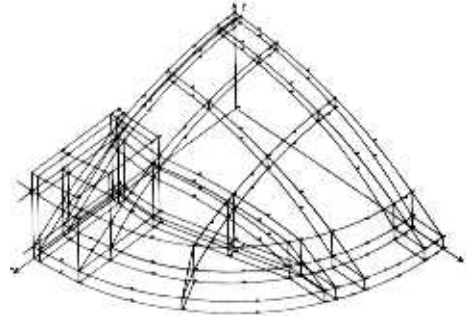
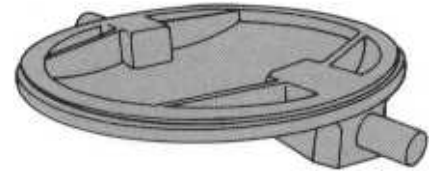

Figure 1: Domed Disc Finite Element Model (quarter section)

The Streamseal Domed Disc Design

The ductile iron domed disc for cast Streamseal Butterfly Valves was developed to enhance disc strength and improve flow characteristics. Elimination of foundry coring was an important factor in the development process, and the resulting design permits the easy inspection, testing and measurement of all disc surfaces. Finite element analysis was used to optimize strength and disc thickness. Head loss and flow coefficients for Streamseal Butterfly Valves are shown on the next page in Fig. 2.



Cast domed disc being machined.

Cast Streamseal™ Butterfly Valve



Continued...

Standard Dimensions

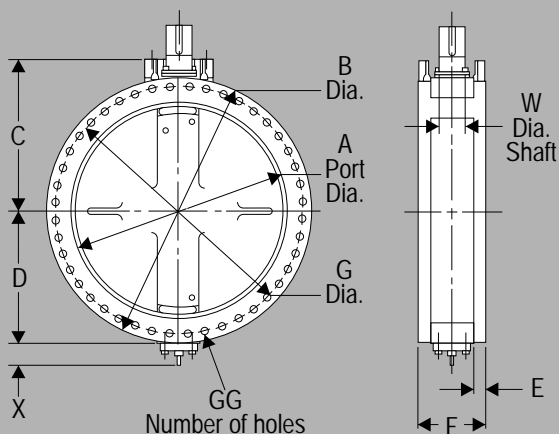

| Size | A | B | C | D | E | F | G | GG | W* | X |
|------|-------|--------|-------|-------|------|-------|--------|----|-------|------|
| 24 | 22.88 | 32.00 | 21.75 | 16.25 | 1.88 | 8.00 | 29.50 | 20 | 3.00 | 6.88 |
| 30 | 29.00 | 38.75 | 24.75 | 19.62 | 2.12 | 12.00 | 36.00 | 28 | 3.62 | 6.88 |
| 36 | 34.94 | 46.00 | 27.88 | 23.25 | 2.38 | 12.00 | 42.75 | 32 | 4.50 | 6.88 |
| 42 | 40.88 | 53.00 | 30.88 | 26.75 | 2.62 | 12.00 | 49.50 | 36 | 5.00 | 6.88 |
| 48 | 46.88 | 59.50 | 34.25 | 29.88 | 2.75 | 15.00 | 56.00 | 44 | 5.75 | 6.88 |
| 54 | 52.88 | 66.25 | 37.75 | 33.38 | 3.00 | 15.00 | 62.75 | 44 | 6.75 | 7.31 |
| 60 | 58.88 | 73.00 | 40.88 | 36.75 | 3.12 | 15.00 | 69.25 | 52 | 7.50 | 7.56 |
| 66 | 64.88 | 80.00 | 44.50 | 40.50 | 3.38 | 18.00 | 76.00 | 52 | 7.75 | 7.56 |
| 72 | 70.88 | 86.50 | 47.62 | 43.62 | 3.50 | 18.00 | 82.50 | 60 | 8.50 | 6.02 |
| 78 | 76.88 | 93.25 | 50.25 | 47.00 | 3.75 | 21.00 | 89.00 | 64 | 9.25 | 6.02 |
| 84 | 82.88 | 99.75 | 60.00 | 55.00 | 3.88 | 21.00 | 95.50 | 64 | 10.00 | 6.02 |
| 90 | 88.88 | 106.50 | 55.88 | 53.50 | 4.06 | 22.50 | 102.00 | 68 | 10.75 | 6.02 |
| 96 | 94.00 | 113.25 | 60.00 | 57.25 | 4.25 | 24.00 | 108.50 | 68 | 11.50 | 6.02 |

*Shaft dimensions for 150B rating.

Dimensions in inches.

Valve may be installed with shaft in either the horizontal or vertical position.

Streamseal Butterfly Valve with Domed Disc – Head Loss and Flow Coefficients

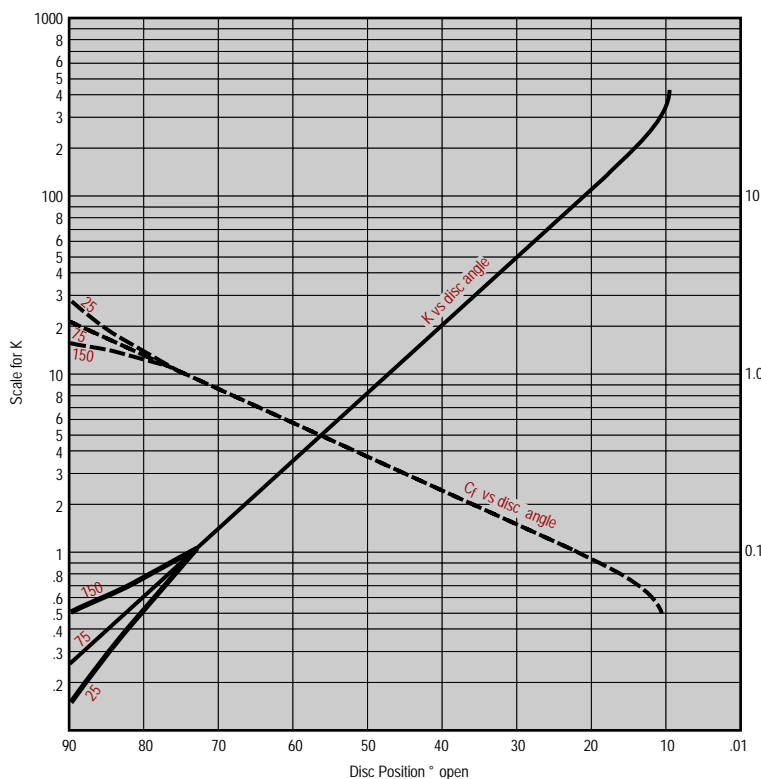

K and C_f versus disc position

$$H_L = \frac{Kv^2}{2g} = \frac{V^2}{2gC_f^2}$$

H_L = head loss across valve in feet of water

K = head loss coefficient

C_f = flow coefficient

V = fluid velocity in pipe in feet per second

g = gravitational constant (32.2) feet per sec.²

NOTE: Actual performance of the valve will be affected by the parameters of the complete system.

Figure 2

Materials

Body MaterialASTMA126, Class B Cast Iron

Disc MaterialASTMA536, Grade 65-45-12

Ductile Iron

ShaftASTMA276, Type 304 Stainless Steel

Seat MaterialBuna-N

Shaft SealsConventional packing with bronze gland

Mating Seat Surface....ASTMA276, Type 304 Stainless Steel

Shaft BearingsCorrosion resistant, self-lubricated sleeve type

CoatingHigh solids, high build epoxy
other materials available upon request to meet system requirements.

End Configurations

Flanged (ANSI-B16.1 Class 125), mechanical joint (AWWA C110), grooved, plain, metric flanges, higher pressure rated flanges.

Sizes

24", 30", 36", 42", 48", 54", 60", 66", 72", 78", 84", 90", 96", 108", 120". (metric sizes also available).

Pressure Classes

25, 75, 150, 250 psi

Testing

AWWA C504 (latest edition)

Streamseal™ Butterfly Valve



Rubber-covered 24" and Larger

Rodney Hunt rubber-covered Streamseal Butterfly Valves are designed for the most corrosive service applications. Two distinct layers of rubber (Fig. 3) protect all ferrous metal parts exposed to corrosive liquid. This layered rubber covering is applied to all wetted surfaces of body, disc, and end cover. A tie-gum or soft rubber underlayment provides a strong bond between the grit blasted base metal and the rubber outer layer.

The soft rubber underlayment allows for some flexibility (65 Shore A Durometer). The hard rubber (43 to 70 Shore D Durometer) outer layer provides a non-hygroscopic, machineable, and rugged covering, extending into all areas of body and disc, including close tolerance locations (shaft bores, thrust bearing recess, and stuffing box). The entire cover is bonded in place, then vulcanized for absolute adhesion of rubber to metal.

All rubber-covered surfaces are given a dielectric spark test (before and after vulcanization) to ensure complete coverage.

Applications

Rubber-covered Streamseal Butterfly Valves are used in a variety of process applications to control the flow of corrosive fluids. Figure 4 shows potential process locations in a typical circulating water service, where prolonged reuse of water progressively increases mineral content, or where the original water source is saline or brackish.

Figure 5 illustrates a condenser partition valve installation, where the actuator is located externally from the condenser.

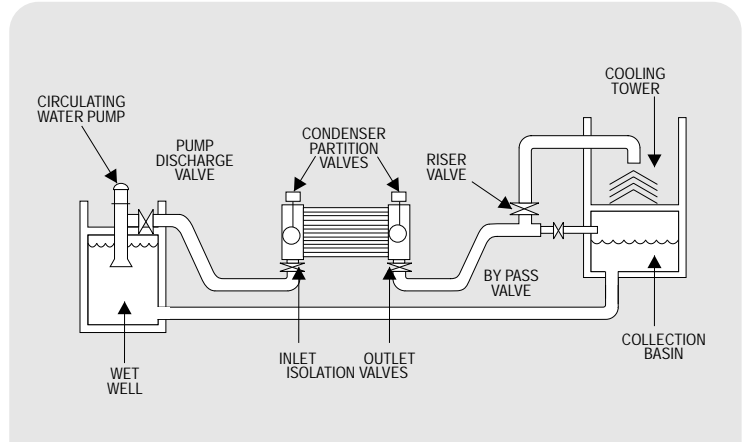

Figure 4: Typical Circulating Water System

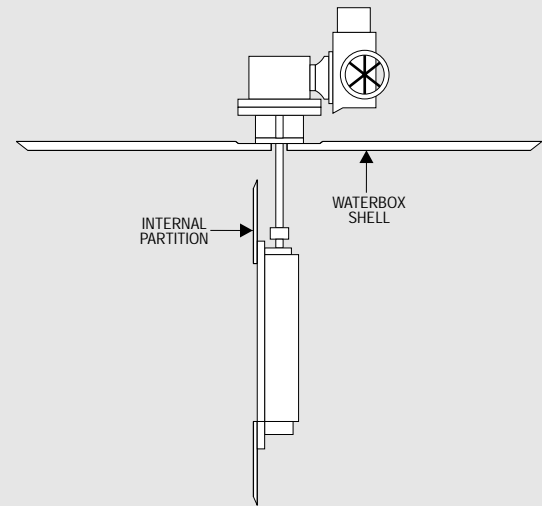

Figure 5: Condenser Partition Valve – Typical Installation

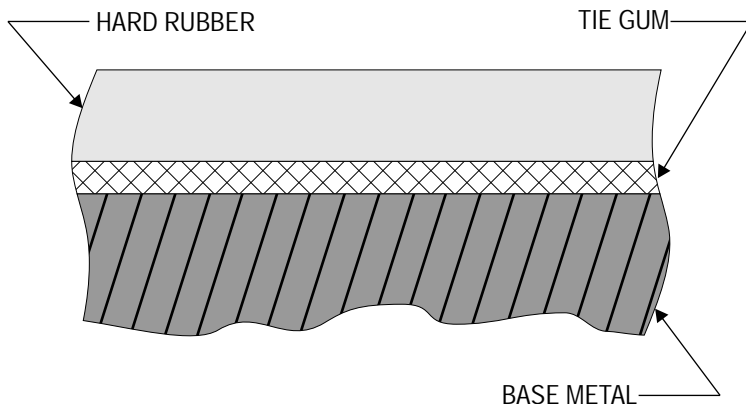

Figure 3: Cross Section

Streamseal™ Butterfly Valve



Rubber-covered *continued...*

Standard Dimensions

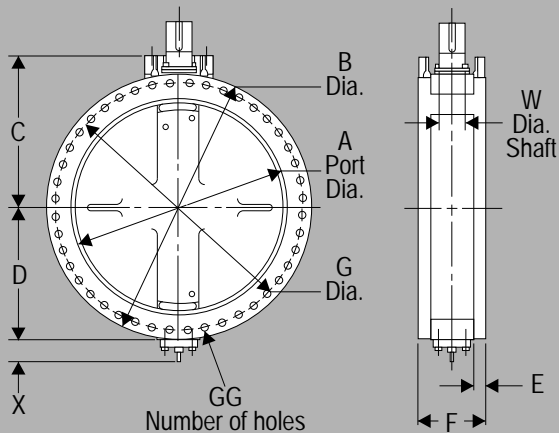

| Size | A | B | C | D | E | F | G | GG | W* | X |
|------|-------|--------|-------|-------|------|-------|--------|----|-------|------|
| 24 | 22.88 | 32.00 | 21.75 | 16.25 | 1.88 | 8.00 | 29.50 | 20 | 3.00 | 6.88 |
| 30 | 29.00 | 38.75 | 24.75 | 19.62 | 2.12 | 12.00 | 36.00 | 28 | 3.62 | 6.88 |
| 36 | 34.94 | 46.00 | 27.88 | 23.25 | 2.38 | 12.00 | 42.75 | 32 | 4.50 | 6.88 |
| 42 | 40.88 | 53.00 | 30.88 | 26.75 | 2.62 | 12.00 | 49.50 | 36 | 5.00 | 6.88 |
| 48 | 46.88 | 59.50 | 34.25 | 29.88 | 2.75 | 15.00 | 56.00 | 44 | 5.75 | 6.88 |
| 54 | 52.88 | 66.25 | 37.75 | 33.38 | 3.00 | 15.00 | 62.75 | 44 | 6.75 | 7.31 |
| 60 | 58.88 | 73.00 | 40.88 | 36.75 | 3.12 | 15.00 | 69.25 | 52 | 7.50 | 7.56 |
| 66 | 64.88 | 80.00 | 44.50 | 40.50 | 3.38 | 18.00 | 76.00 | 52 | 7.75 | 7.56 |
| 72 | 70.88 | 86.50 | 47.62 | 43.62 | 3.50 | 18.00 | 82.50 | 60 | 8.50 | 6.02 |
| 78 | 76.88 | 93.25 | 50.25 | 47.00 | 3.75 | 21.00 | 89.00 | 64 | 9.25 | 6.02 |
| 84 | 82.88 | 99.75 | 60.00 | 55.00 | 3.88 | 21.00 | 95.50 | 64 | 10.00 | 6.02 |
| 90 | 88.88 | 106.50 | 55.88 | 53.50 | 4.06 | 22.50 | 102.00 | 68 | 10.75 | 6.02 |
| 96 | 94.00 | 113.25 | 60.00 | 57.25 | 4.25 | 24.00 | 108.50 | 68 | 11.50 | 6.02 |

*Shaft dimensions for 150B rating.

Dimensions in inches.

Valve may be installed with shaft in either the horizontal or vertical position.

Where Rubber-covered Butterfly Valves are Typically Used

- Circulating water service (Figure 4)
- Condenser partition (Figure 5)
- Condenser isolation
- Wet well service
- For control of saline and brackish water within the plant or intake structure.

Sizes - Pressure Classes - Testing

Sizes Cast: 24", 30", 36", 42", 48", 54", 60", 66", 72", 78", 84", 90", 96", 108", 120",

Fabricated: 24" and larger

Pressure Classes 25, 75, 150, 250 psi

Painting High-build, high-solids epoxy.

Testing In accordance with AWWA C504.

Optional MSS SP-67 available

Higher pressures available upon request.

Disc Design: Domed, Flow Through or Low-Profile

All disc configurations are offered with lock-in rubber seat, tangential pinning and full rubber covering.

Domed Disc: Constructed from ductile iron, the domed disc was developed to enhance the strength and improve the flow characteristics of cast valves.

Flow-Through: Constructed from fabricated steel, the Flow Through disc features a rugged bridge truss and flow-through area easily accessible for rubber covering.

Low Profile: Constructed from fabricated steel, the Low Profile disc features a streamlined disc profile with heavy trunnions.

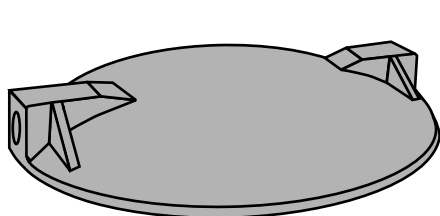

DOMED DISC

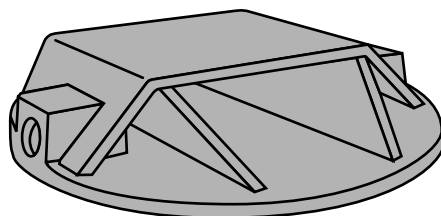

FLOW-THROUGH DISC

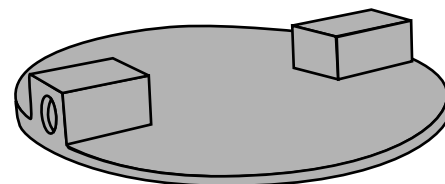

LOW PROFILE DISC

Figure 6: Disc Configurations

Fabricated Streamseal™ Butterfly Valve



Custom Engineered and Pre-Engineered

24" and Larger

Custom engineered fabricated Streamseal Butterfly Valves are designed for a variety of plant services requiring special materials, sizes and end configurations.

- In-house system analysis, design, and manufacturing experience. Rodney Hunt has the hydraulic engineering expertise to analyze system requirements. Utilizing designs, data, and technical history acquired from Allis Chalmers, Rodney Hunt will recommend the appropriate valve for the application. The latest design technologies, including finite element analysis, facilitate the development of final custom designs.
- Cost-effective flow control for a wide range of flows, pressures, temperatures and media. Fabricated valves can be designed and manufactured to control flows with virtually unlimited pressure and temperature ranges. Liquids containing abrasive solids or entrained gas can be effectively handled.
- Available in other than "standard" sizes. Fabricated valves can be designed to meet equipment and space limitations.
- Permits varied or mixed-end configurations. Fabricated valves are custom engineered for each application, and can incorporate ANSI or metric flanges, wafer, weld ends, or other configurations to connect to adjacent equipment or piping.
- Materials of construction flexibility. Available in steel, stainless steel, or more sophisticated metals as required for specific service conditions. Process conditions (or combination of conditions) such as high temperature or abrasive solids may require custom designed resilient-to-metal or metal-to-metal seating.
- Rubber coating available for corrosive service. A dual rubber coating on all interior wetted areas is available to resist corrosion in brine, saline, or other aggressive services. Allis-Chalmers rubber-covered butterfly valves have been successfully used for power and desalination plant service since 1937.
- Total actuation availability. Rodney Hunt has the expertise to analyze requirements, design, manufacture, mount, test, calibrate, and install all types of actuation systems: manual, electric, cylinder (pneumatic, hydraulic, or air/oil). Extension stems or extended bonnets for open/close or modulating service are also available.



Finite element analysis software enables the static and dynamic assessment of a product or component under various loading and stress conditions.

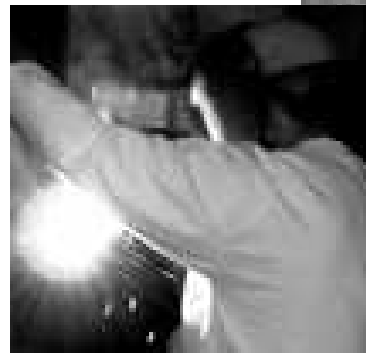

Fabricated Streamseal butterfly valves can be manufactured to meet a variety of service conditions.

All Rodney Hunt welders meet AWS and ASME, Section IX qualifications.

for Valve Operation

Depending upon the application, Rodney Hunt hydraulic systems for valve control offer specific advantages and economies over manual and electric actuation. Where several valves are operated by a single hydraulic operating system, for example, considerable cost savings can result.

Rodney Hunt has the capability to design, manufacture, and test hydraulic systems complete with associated electrical control panels. Start-up assistance is also available. These capabilities offer the consulting engineer, contractor, and end-user single-source responsibility for both the valve equipment and hydraulic actuation.

Advantages of Hydraulic Actuation

- Inexpensive. Hydraulic actuation is the most cost effective type of actuation currently available (other than manual).
- Standard components. Pre-engineered cylinders are available for valve operation in any application.
- Increased control. Valve can be designed to open and close at different speeds, and to permit easy field adjustment of speed.
- Less wear. Hydraulic cylinders provide long, trouble free service especially where valve opens /closes frequently, or for modulating service.
- Flexible functions. Systems can vary from a simple pushbutton station to sophisticated programmable positioning.
- Emergency "fail-safe" operation. Can be easily configured to open or close valve in the event of power failure, line break, or other emergency.
- Added security. Ideally suited for environments that require explosion-proof equipment. The hydraulic system can be housed in a remote location.



Hydraulic actuation system engineering includes development of hydraulic power units that respond to computer instructions for exact valve positions, continuous monitoring, and emergency operation.

Manual or Power Actuation

& Accessories



Manual-In accordance with AWWA C504 Standard.

Handwheel, chain-wheel, or operating nut input. Adjustable travel stops, and self locking feature.

Electric Motor-Available for open-close or throttling service, complete with limit switches and torque switch as required.

Manual override is standard. Also available for modulating service with position feedback for continuously adjustable automatic controls. Complete accessories are available and include indicator lights, integral reversing starters, push buttons, potentiometers, space heaters, sensors, transmitters, transducers and other control features.

Cylinder-Pneumatic or hydraulic; suitable for plant air, water, or oil operating media. Controls available for adjustable closure rates. Complete hydraulic power units are available. Control systems can be supplied for automatic fail-safe closure and valve positioning. Position sensors can also be provided.

Extension Bonnet and Shaft-For locating actuator away from valve for easy access. Actuator (manual or power) is mounted on end of extension bonnet and coupled to the extended valve shaft.

Extended Actuator Input Shaft-Manual actuator is mounted on valve with valve shaft horizontal.

Actuator input shaft may be extended to a floorstand with handwheel or electric actuator.

Extended Valve Shaft - Vertical valve shaft may be extended away from valve with couplings or universal joints and connected to a floorstand-mounted manual, electric or cylinder actuator.

Also available:

- Floorstands
- Wall Brackets
- Chain-wheel Sprocket and Guide
- Torque Tube
- Integral Disc Position Indicator
- Rodney Hunt Epoxy Coating
- Special Paint Requirements

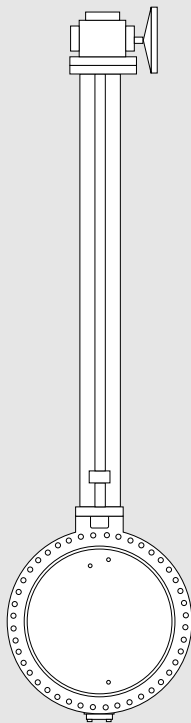

EXTENSION BONNET AND SHAFT

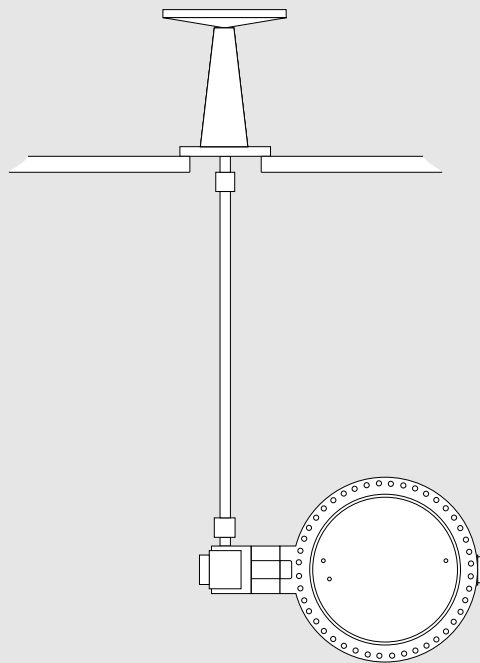

EXTENDED ACTUATOR INPUT SHAFT

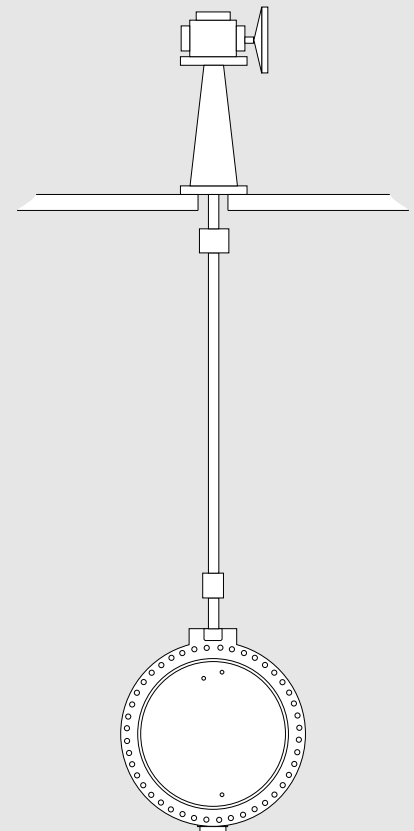

EXTENDED VALVE SHAFT

Figure 7: Valve Extensions

Manual or Power Actuation



continued...

Manual Actuators.

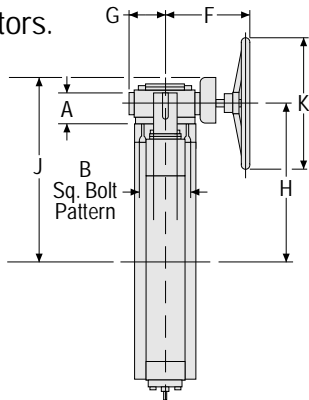

Actuator dimensions are approximate. Request certified drawings for space requirements

| Size | A | B | C | D | E | F | G | H | J | K |
|------|-------|-------|-------|-------|-------|-------|-------|-------|-------|----|
| 24 | 6.50 | 6.25 | 6.75 | 3.50 | 4.25 | 11.50 | 3.50 | 25.00 | 28.75 | 24 |
| 30 | 6.50 | 9.88 | 9.10 | 6.00 | 5.50 | 14.50 | 6.75 | 28.88 | 33.50 | 24 |
| 36 | 6.50 | 9.88 | 8.10 | 6.00 | 5.50 | 16.75 | 6.75 | 32.00 | 37.38 | 24 |
| 42 | 6.50 | 9.88 | 9.50 | 7.10 | 6.75 | 16.75 | 6.75 | 35.00 | 40.38 | 24 |
| 48 | 8.88 | 12.25 | 11.25 | 8.50 | 8.10 | 17.75 | 7.75 | 38.65 | 44.00 | 24 |
| 54 | 8.88 | 12.25 | 12.75 | 8.50 | 9.10 | 19.75 | 9.25 | 42.50 | 49.75 | 36 |
| 60 | 8.88 | 12.25 | 15.75 | 9.75 | 11.50 | 23.00 | 10.75 | 48.60 | 53.38 | 24 |
| 66 | 10.00 | 14.62 | 19.50 | 11.38 | 14.00 | 29.38 | 14.75 | 54.10 | 60.10 | 24 |
| 72 | 10.00 | 14.62 | 19.50 | 11.38 | 14.00 | 29.38 | 14.75 | 57.25 | 63.25 | 30 |
| 78 | 10.00 | 17.50 | 19.50 | 11.38 | 14.00 | 29.38 | 14.75 | 58.38 | 64.38 | 36 |
| 84 | 12.00 | 17.50 | 22.38 | 11.75 | 16.00 | 33.75 | 14.25 | 70.00 | 79.88 | 36 |
| 90 | 12.00 | 18.50 | 24.75 | 15.50 | 18.00 | 36.38 | 16.75 | 66.75 | 76.50 | 36 |
| 96 | 12.00 | 20.00 | 24.75 | 15.50 | 18.00 | 36.38 | 16.75 | 71.00 | 80.75 | 30 |

Dimensions in inches.

Cylinder Actuators.

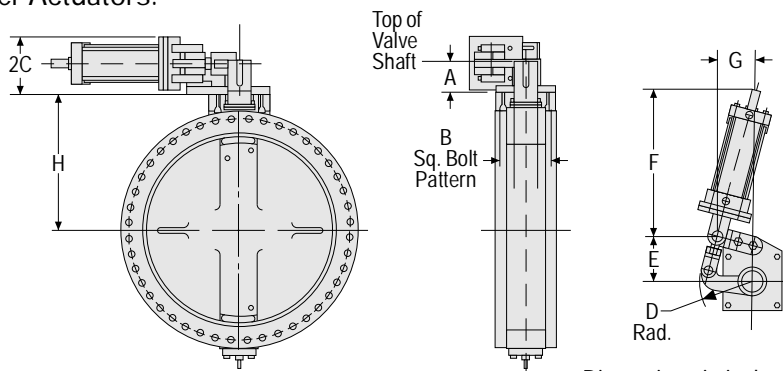

| Size | A | B | C | D | E | F | G | H |
|------|-------|-------|------|-------|-------|-------|-------|-------|
| 24 | 6.50 | 6.25 | 2.50 | 10.12 | 9.19 | 25.00 | 7.13 | 21.75 |
| 30 | 6.50 | 9.88 | 2.50 | 10.12 | 9.19 | 25.00 | 7.13 | 24.75 |
| 36 | 6.50 | 9.88 | 2.50 | 10.12 | 9.19 | 25.00 | 7.13 | 27.88 |
| 42 | 6.50 | 9.88 | 2.50 | 10.12 | 9.19 | 25.00 | 7.13 | 30.88 |
| 48 | 8.88 | 12.25 | 3.75 | 17.38 | 15.56 | 34.00 | 12.56 | 34.25 |
| 54 | 8.88 | 12.25 | 3.75 | 17.38 | 15.56 | 34.00 | 12.56 | 37.75 |
| 60 | 8.88 | 12.25 | 3.75 | 17.38 | 15.56 | 34.00 | 12.56 | 40.88 |
| 66 | 10.00 | 14.62 | 4.25 | 24.12 | 20.96 | 45.00 | 18.19 | 44.50 |
| 72 | 10.00 | 14.62 | 4.25 | 24.12 | 20.96 | 45.00 | 18.19 | 47.62 |
| 78 | 10.00 | 17.50 | 4.25 | 24.12 | 20.96 | 45.00 | 18.19 | 50.25 |
| 84 | 12.00 | 17.50 | 5.25 | 31.38 | 27.63 | 74.00 | 23.25 | 60.00 |
| 90 | 12.00 | 18.50 | 5.25 | 31.38 | 27.63 | 74.00 | 23.25 | 55.88 |
| 96 | 12.00 | 20.00 | 5.25 | 31.38 | 27.63 | 74.00 | 23.25 | 60.00 |

Dimensions in inches.

Electric Actuators.

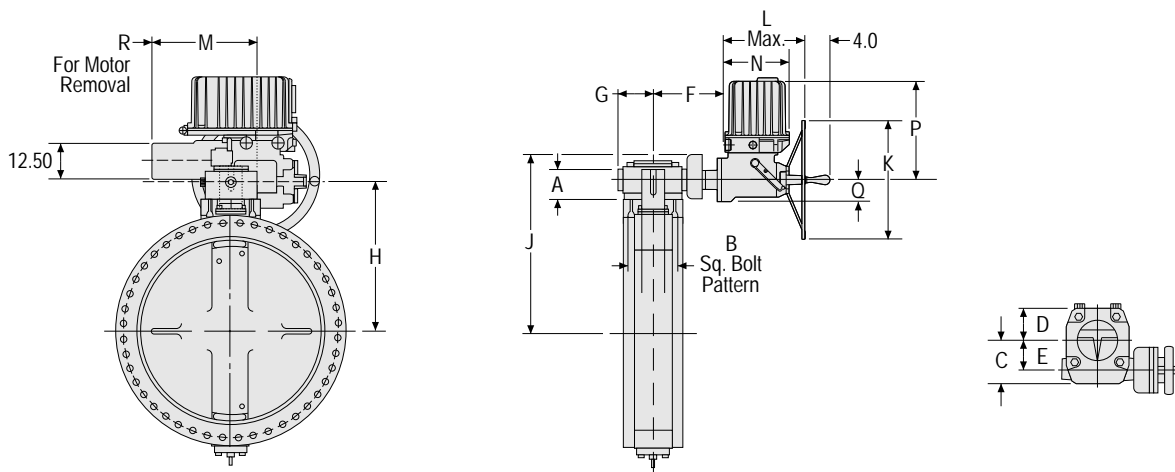

| Size | A | B | C | D | E | F | G | H | J | K | L | M | N | P | Q | R |
|------|-------|-------|-------|-------|-------|-------|-------|-------|-------|----|-------|-------|-------|-------|------|------|
| 24 | 6.50 | 6.25 | 6.75 | 3.50 | 4.25 | 11.50 | 3.50 | 25.00 | 28.75 | 12 | 12.10 | 14.25 | 10.62 | 15.13 | 2.50 | 2.50 |
| 30 | 6.50 | 9.88 | 9.10 | 6.00 | 5.50 | 14.50 | 6.75 | 28.88 | 33.50 | 12 | 12.10 | 14.25 | 10.62 | 15.13 | 2.50 | 2.50 |
| 36 | 6.50 | 9.88 | 8.10 | 6.00 | 5.50 | 16.75 | 6.75 | 32.00 | 37.38 | 12 | 12.10 | 14.25 | 10.62 | 15.13 | 2.50 | 2.50 |
| 42 | 6.50 | 9.88 | 9.50 | 7.10 | 6.75 | 16.75 | 6.75 | 35.00 | 40.38 | 18 | 13.60 | 16.00 | 11.00 | 16.13 | 3.50 | 2.50 |
| 48 | 8.88 | 12.25 | 11.25 | 8.50 | 8.10 | 17.75 | 7.75 | 38.65 | 44.00 | 18 | 13.60 | 16.00 | 11.00 | 16.13 | 3.50 | 2.50 |
| 54 | 8.88 | 12.25 | 12.75 | 8.50 | 9.10 | 19.75 | 9.25 | 42.50 | 49.75 | 24 | 14.00 | 18.90 | 11.00 | 16.75 | 3.50 | 2.50 |
| 60 | 8.88 | 12.25 | 15.75 | 9.75 | 11.50 | 23.00 | 10.75 | 48.60 | 53.38 | 18 | 15.50 | 31.13 | 10.13 | 15.75 | 4.13 | 4.00 |
| 66 | 10.00 | 14.62 | 19.50 | 11.38 | 14.00 | 29.38 | 14.75 | 54.10 | 60.10 | 18 | 15.50 | 31.13 | 10.13 | 15.75 | 4.13 | 4.00 |
| 72 | 10.00 | 14.62 | 19.50 | 11.38 | 14.00 | 29.38 | 14.75 | 57.25 | 63.25 | 18 | 15.75 | 32.25 | 10.75 | 18.13 | 6.75 | 4.00 |
| 78 | 10.00 | 17.50 | 19.50 | 11.38 | 14.00 | 29.38 | 14.75 | 58.38 | 64.38 | 18 | 15.75 | 32.25 | 10.75 | 18.13 | 6.75 | 4.00 |
| 84 | 12.00 | 17.50 | 22.38 | 11.75 | 16.00 | 33.75 | 14.25 | 70.00 | 79.88 | 24 | 19.38 | 39.50 | 12.25 | 27.88 | 9.25 | 4.00 |
| 90 | 12.00 | 18.50 | 24.75 | 15.50 | 18.00 | 36.38 | 16.75 | 66.75 | 76.50 | 24 | 19.38 | 39.50 | 12.25 | 27.88 | 9.25 | 4.00 |
| 96 | 12.00 | 20.00 | 24.75 | 15.50 | 18.00 | 36.38 | 16.75 | 71.00 | 80.75 | 24 | 19.38 | 39.50 | 12.25 | 27.88 | 9.25 | 4.00 |

Dimensions in inches.

24" and Larger Butterfly Valves

Butterfly valves shall be rubber-seated tight closing Streamseal Valves as manufactured by Rodney Hunt Company, and shall conform to AWWA Standard C504 latest revision.

The butterfly valve bodies shall be of cast iron ASTM A126 Class B. They shall have integral hubs for housing shaft bearings and seals. Body ends shall be either: flanged with facing and drilling in accordance with ANSI B16.1, Class 125, or mechanical joint in accordance with AWWA Standard C110.

Butterfly valve discs shall be of the "off-set" design to provide a full 360° uninterrupted seating surface. Discs shall be Ductile iron ASTM A536, Grade 65-45-12 with no external ribs transverse to the flow.

All cast discs shall be the uncored type so that all disc surfaces are exposed for easy inspection and/or measurement.

The resilient seat shall be synthetic rubber designed to provide tight shut-off at the pressures specified in the data table. Seat shall be incorporated on the valve disc edge and shall be mechanically retained by means of a corrosion-resistant ring, and stainless steel screws.

The resilient seat must be capable of mechanical adjustment in each direction without the use of special tools. It must also be capable of being replaced in the field without chipping, grinding, or burning out of the old seat, moving the valve disc along its shaft axis, or removing the valve from the line.

The mating seat surface shall be integral with the valve body and shall be stainless steel, Type 304. Sprayed or plated mating seat surfaces are not acceptable.

Valve shafts shall be of the two-piece type extending into the valve disc hubs for a distance of at least one and one-half shaft diameters. They shall be of stainless steel, Type 304.

Valve shafts shall be securely attached to the valve disc by means of taper pins located tangentially to the valve shafts. Taper pins shall be mechanically secured and shall be of corrosion-resistant material.

Shaft bearings shall be contained in the integral hubs of the valve body. They shall be of the self-lubricated, sleeve type.

The valve assembly shall be furnished with a factory-set two-way thrust bearing which is field adjustable.

Where the valve shaft projects through the body for the operator connection, a shaft seal shall be provided. The seal shall be of the type utilizing a stuffing box and pull down package gland so that the package can be adjusted or completely replaced without disturbing any part of the valve or operator assembly except the packing gland follower.

Actuator will be sized to operate the valve from full open to full closed at rated pressure with a maximum of 80 ft./lb. of input torque on a manual actuator. The valve manufacturer shall be responsible for sizing electric or cylinder operators based on flow and pressure conditions.

Coating shall be of two (2) layers (5 mils minimum each coat). First coat interior and exterior to be Amine Modified Polyamide Epoxy Amerlock 400, or approved equivalent. Second coat shall be the same as the first coat unless the valve is exposed to sunlight, in which case the second coat exterior shall be Aliphatic Polyurethane Amercoat 450 H.S. or approved equivalent.

Rubber-covered Butterfly Valves

NOTE: The following specifications apply only to rubber-covered butterfly valves. Refer to Standard Specifications found above for complete butterfly valve specifications.

When the valve is to be used in corrosive service, a multi-ply rubber covering shall be vulcanized to all interior wetted surfaces of the valve body, disc and end cover for corrosion protection. The rubber shall extend into all areas of the body and disc including hard-to-reach, close-tolerance locations such as shaft bores, thrust bearing recess, stuffing box, etc., so that all internal wetted surfaces are isolated from the corrosive flow medium without dependence upon dynamic O-Ring seals.

All surfaces to be rubber-covered shall first be thoroughly grit blasted to SSPC-SP5 (white metal blast) prior to coating. The layered rubber shall consist of a soft rubber or tie-gum underlayment of approximately 65 on the Shore A Durometer scale, and a hard rubber outer layer of approximately 43 to 70 on the Shore D Durometer scale. The rubber shall be bonded to the clean grit blasted base metal, then vulcanized to form a solid covering to face the corrosive flow medium, and to resist the absorption of water. Final lining thickness shall be 3/16" minimum when measured at any point. The coating shall be spark-tested at 20,000 volts to assure coating integrity. The body rubber covering shall terminate in a machined recess in the face of each flange, and shall be flush with the flange face.

When in the closed position, the resilient seat shall mate against a seating surface that is machined into the hard rubber body covering.